

# Support system HMAX

## Data sheet

### Function:

Support for the installation of all types of coverings, especially stone slabs and wooden structures. Height adjustment using compensating rings makes it easy to level out any unevenness in the foundations and any slopes. This support can be installed directly on the damp-proofing membrane. Protective mats are not required in areas subject to normal wear and tear (additional protective mats must be fitted in areas frequented by the public, such as entrances to public buildings, cafeterias, etc.).

### Options:

Joint divider widths 3 mm and 4 mm, removable joint divider wings

KALA wood: a level surface without wings fitted under wooden components

### Packing:

PE plastic bag

# KALA®

*Ideas for  
the roofs!*

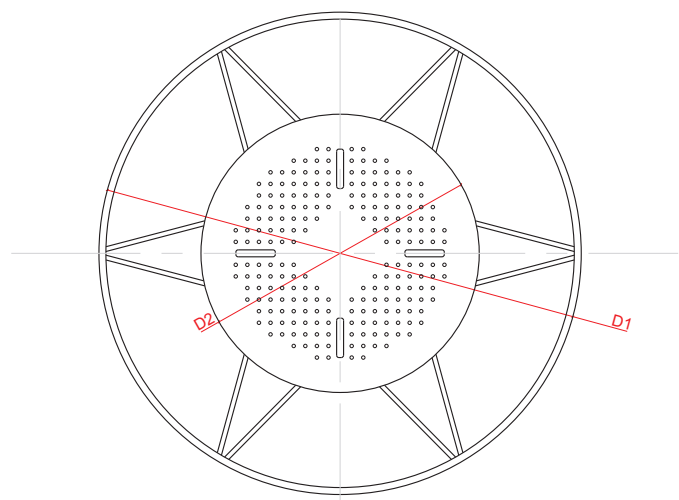
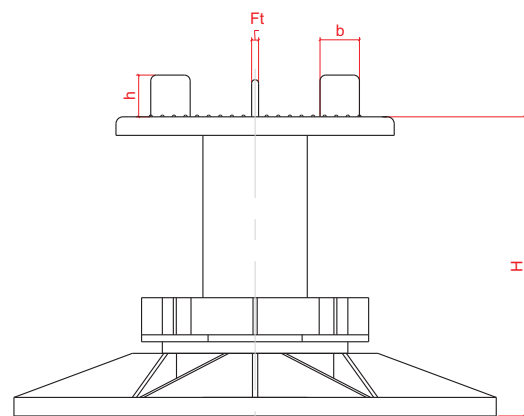

Support system HMAX

	HMAX 65-100	HMAX 95-130	HMAX 125-160	HMAX 155-190	HMAX 185-220	
D1	208	208	208	208	208	mm
D2	120	120	120	120	120	
H	65-100	95-130	125-160	155-190	185-220	
h	18	18	18	18	18	
b	17	17	17	17	17	
Ft	3	3	3	3	3	

For further information please call your KALA technical advisor.

KALA, K.-H. Lange GmbH+Co.KG reserves the right to any change as may be technically or legally required without prior notice.

Last update: October 2009

KALA - KUNSTSTOFFE  
K.-H. Lange GmbH + Co. KG

Am Römerhof 19  
D - 78727 Oberndorf

Phone +49 7423 8687-0  
Fax +49 7423 8687-88

info@kala.de  
www.kala.de